

## Architecture of a DSP Based Dual-Mode ATSC/NTSC Television Exciter and Transmitter

David L. Hershberger  
Continental Electronics, Inc.  
Grass Valley, California

### I. Introduction

The FCC has mandated a period during which ATSC and NTSC signals will be simulcast. After the transition period, the NTSC signal will be discontinued. In some cases, at the end of the transition period, the ATSC signal will move to the NTSC channel. Transmission equipment that is suitable for both NTSC and ATSC broadcasts will provide the greatest degree of flexibility for the broadcaster.

When designing hardware to produce ATSC signals, a little extra thought, and a little extra hardware will allow use of the same platform to produce both ATSC and NTSC signals. Novel combinations of modern Field-Programmable Gate Arrays, (FPGAs), general purpose digital signal processors, and programmable digital filter parts make possible the development of a flexible signal generation system that can produce either analog or digital TV IF signals.

### II. System Requirements

A digital television (DTV) transmitter includes many subsystems, including:

1. Digital line receiver (SMPTE 310M)
2. Data randomizer
3. Reed-Solomon encoder
4. Data interleaver
5. Trellis coder
6. Sync inserter
7. 8-VSB modulator
8. Up converter
9. RF power amplifier
10. Adaptive linear equalizer
11. Adaptive nonlinear equalizer
12. Channel filter
13. Power supply
14. Control system
15. Embedded software

Although all of the above functions are included in a DTV transmitter, the emphasis of this paper is on the vestigial sideband modulator.

Before we look at ways that might be used to produce TV signals in the digital domain, we will review one of the most important parts of a DTV exciter: the filter or set of filters that produce the vestigial sideband shape.

To ensure that the receiver has a maximum eye opening, minimum error vector magnitude (EVM), and makes most efficient use of the available bandwidth, the overall frequency response shape from the transmitter to the receiver has been defined as a flat amplitude channel with raised cosine shaped band edges. However, both the transmitter and the receiver must have bandpass filters. The transmitter needs a bandpass filter to limit and shape its emitted spectrum. The receiver needs a bandpass filter to select the desired received signal and reject others.

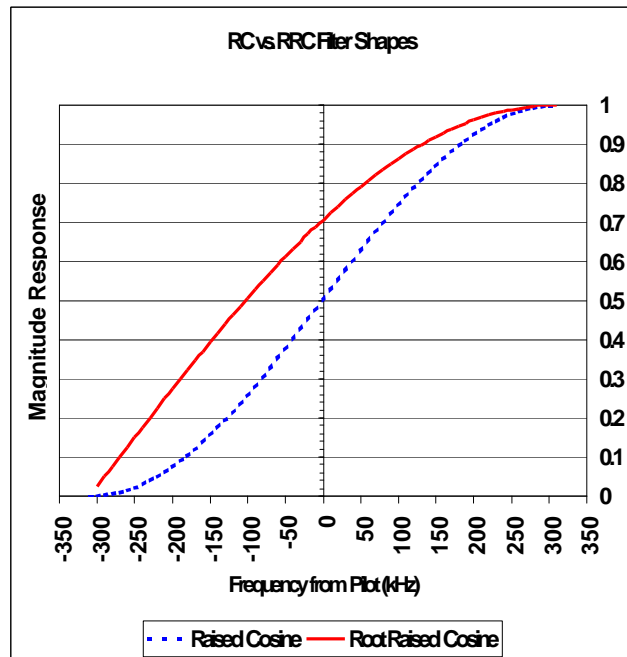
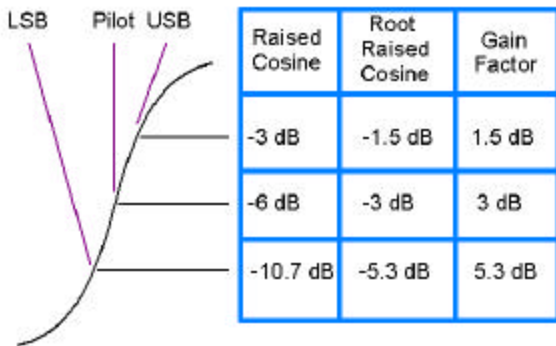

**Figure 1 - Raised Cosine vs. Root Raised Cosine  
Filtering**

To obtain the desired raised cosine response, the transmitter and receiver responses are multiplied. If both

filters were raised cosine, then the overall shape would be raised cosine squared. But if both filters have a response that is the square root of the desired response, then the combined response will be the desired response. This is why the transmitter (and receiver) must have a [square] root raised cosine response in their transition bands. The difference between a raised cosine and a root raised cosine spectral shape is shown in Figure 1.

Most bandpass filters and lowpass filters have a passband (ripple amplitude) specification and a stopband (out of band attenuation) specification. The shape of the filter response in the transition band, between these two passband and stopband regions, is usually not specified, and the particular shape ends up being whatever allows the passband and stopband areas to be optimized. But in ATSC, the transition band is also specified (as root raised cosine), which makes the filter more complicated because its response must meet a certain shape *everywhere*, not just in the passband and stopband. As a result, the root raised cosine filter generally requires more coefficients than conventional filters that leave the transition band unspecified.



**Figure 2 – Root Raised Cosine Equalization**

Figure 2 shows the difference in the transition bands between a raised cosine (RC) response and a root raised cosine (RRC) response. The numbers in the first column show the response of a RC filter at various points. The second column shows the response of a RRC filter at those same points. The third column shows the gain that must be applied to a RC filter to turn it into a RRC filter. The pilot is 6 dB down on a RC filter but only 3 dB down on a RRC filter. The point of this figure is that the gain difference between RC and RRC filtering is not symmetrical about the pilot.

There are several additional requirements and considerations for a digital TV exciter. These include:

1. Linear adaptive filtering. This allows the transmitter to flatten its frequency response automatically, to correct for amplifier mistuning, load variations, etc.
2. Nonlinear adaptive equalization. Nonlinear correction allows power amplifiers to be more efficient for a given distortion level, reduces sideband shoulders, and improves EVM performance.
3. Frequency or phase locking to external references. Where precision frequency control is needed between co-channel stations, GPS locking may be needed.
4. Making RF frequencies independent of input serial bitstream frequency errors. A SMPTE 310M input stream may be off frequency as much as 2.8 ppm. The RF or IF output frequency, however, should not include this error.
5. Channel offsets. To reduce co-channel and/or adjacent channel interference, slight adjustments in the pilot or carrier frequency are sometimes required.
6. Transmission of sync signals in the absence of an input signal. If the SMPTE 310M input signal is momentarily interrupted or lost, sync should continue to be transmitted, to allow receivers to recover faster when the input signal is restored.

A seventh consideration is the subject of this paper:

7. Dual mode operation (NTSC/ATSC)

**III. Signal Generation Methods**

There are several ways to generate vestigial sideband signals using DSP.

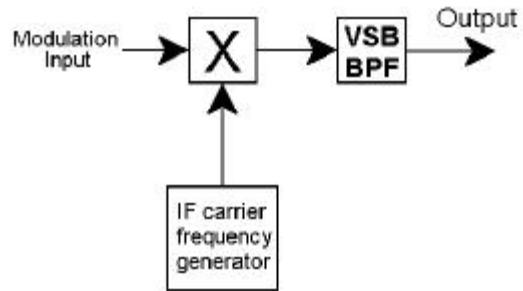

**Figure 3 - Simple VSB Modulator**

The brute force approach would in digital circuitry replicate what is typically done in the analog domain.

This is shown in Figure 3. First, the analog video or digital multilevel baseband signal modulates an IF carrier, producing a double sideband (DSB) signal. Then, the DSB signal is filtered to vestigial sideband (VSB). This simple approach is feasible in DSP but is quite inefficient and costly. Although straightforward, this approach would require a large number of filter taps (in the thousands) at a high sampling rate (40 MHz or more). Clearly, a little finesse is required to do the job efficiently in the digital domain.

Another method is to produce the in-phase and quadrature (I and Q) components of a VSB signal, using the Hilbert transform, as shown in Figure 4.

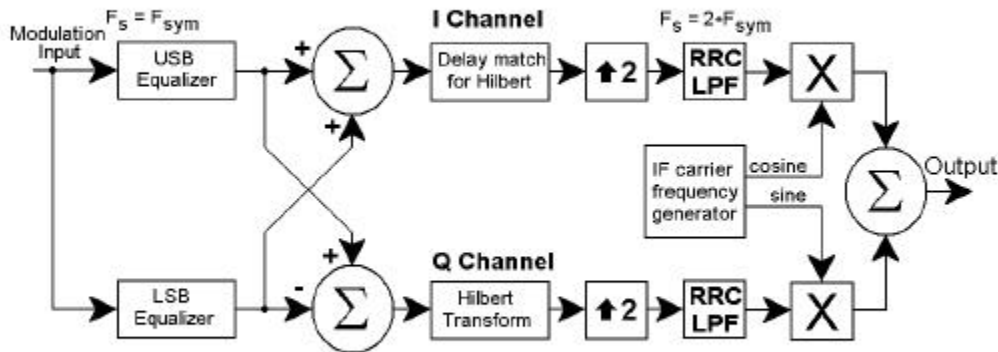

Figure 4 – Hilbert Transform VSB Modulator with RRC Equalization

This method is more practical. A Hilbert transform shifts the phase of frequencies within its passband by 90 degrees. However, since it is impossible to phase shift DC by 90 degrees, there is a practical low frequency limit to the Hilbert transform and it always has zero response at DC. In a quadrature modulator system, the low frequency rolloff and suppression of DC will result in the pilot being down 6 dB instead of the 3 dB required in a RRC spectral shape. So in the case of ATSC signals, special equalizers are required to convert the sideband shape in the vicinity of the pilot (carrier) to a root-raised-cosine response. Strict adherence to the ATSC spectral tail shapes requires the equalizers to have unequal responses for positive and negative frequencies, because the gain function which converts raised cosine to root raised cosine is not symmetrical about the ATSC pilot tone (as shown in Figure 2 above). Figure 4 shows one way to accomplish the equalization, using matrixed equalizers to apply different amounts of gain to the upper and lower sidebands in the vicinity of the pilot.

Hilbert transform modulation produces two baseband signals, each with a bandwidth of approximately 5.69 MHz. As the Nyquist frequency is approximately 5.38 MHz, an interpolation to a higher sampling rate is required to do the RRC shaping of the upper sideband edge without aliasing. Figure 4 shows an interpolation to twice the symbol rate (approximately 21.5 MHz). The blocks with the up-arrows are interpolators, which double the sampling rate.

Hilbert transform VSB modulation is feasible, but the necessary equalizers are rather complex and costly. Also, proper USB spectral shaping requires processing at a sampling rate higher than the symbol rate.

**IV. Weaver Modulation**

Another modulation method, known variously as Weaver modulation and as the so-called "third method" of single-sideband (SSB) generation, can be modified to produce vestigial sideband signals, with any arbitrary sideband shape including root raised cosine.

Weaver modulation was not often used in analog circuits because it requires two accurately matched filters and signal paths. However, in DSP, it is trivial to obtain accurate matching.

Traditional SSB Weaver modulation (shown in Figure 5) begins by multiplying the modulating signal by a pair of quadrature phased sinusoids. When generating SSB, the frequency of the sinusoids is usually the arithmetic mean frequency of the modulating bandwidth. The frequency of these two sinusoids is called the "folding frequency."

This multiplication produces a pair of orthogonal baseband signals. (Figure 5 also shows spectra that exist at various points in the system.) A lowpass filter after each modulator restricts the bandwidth of each output to half the bandwidth of the original modulating signal. At this point, the modulating signal has been "folded," such that the folding frequency is translated to DC while both the upper and lower band edges are translated to the

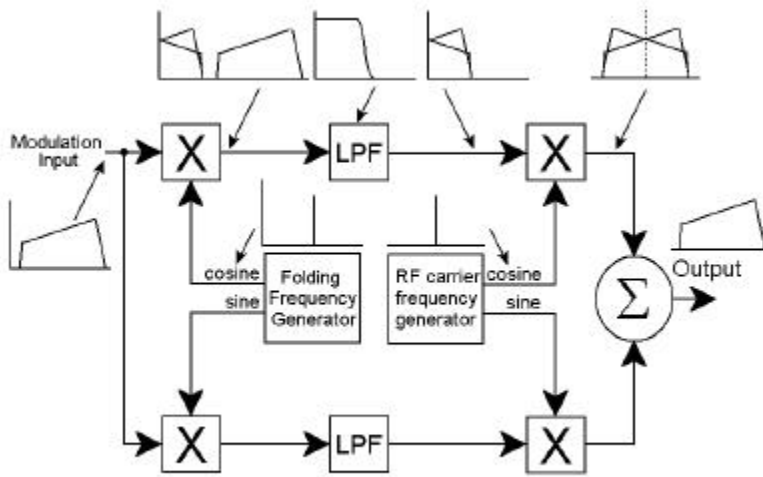

**Figure 5 - Basic Weaver SSB Modulator**

highest frequencies in the folded spectrum. Although two different frequencies map to a single frequency, the (orthogonal) phase relationship between the two baseband signals conveys the information necessary to recreate the modulating signal as SSB.

The two baseband signals are then applied to a pair of mixers driven with quadrature phased versions of an IF or RF signal. If the quadrature phasing is accurate, and if the two lowpass filters are matched, and if the gain, phase, and delay of the two signal paths are matched, then the sum of the two mixers is a SSB signal. The two baseband signals are I and Q signals, although they are offset in frequency from the I and Q signals found in the Hilbert method.

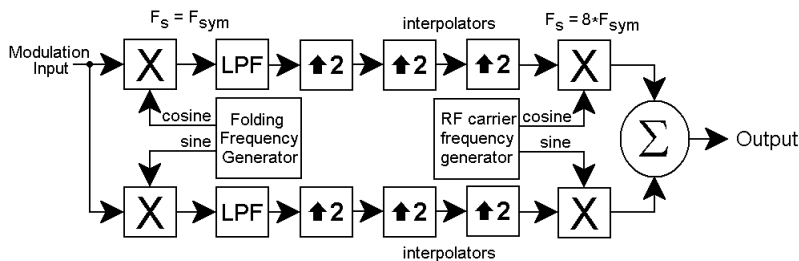

**Figure 6 - 8-VSB Modulator Using the Weaver Method**

Figure 6 shows how Weaver modulation may be applied to generate 8-VSB. To modify the method to create vestigial sideband instead of single sideband, the folding frequency is decreased enough so that a certain

bandwidth of negative frequencies will produce folded frequencies within the bandwidth of the lowpass filters.

The bandwidth of the baseband signals produced by Weaver VSB modulation is only 3 MHz, only about half what it is in the Hilbert transform case. This means that the relatively low symbol rate (approximately 10.76 MHz) may be used to do the RRC filtering, without aliasing.

In the ATSC mode, the 10.76 MHz sampled data is multiplied by orthogonal sinusoids at one quarter of the symbol rate or approximately 2.69 MHz. (The multiplication is relatively trivial, because the folding frequencies may be represented by simple four sample 1,1,-1,-1 sequences.) This produces a pair of folded spectra, each having a bandwidth of just half the

channel width, or 3 MHz. Root raised cosine lowpass filtering (as opposed to bandpass filtering) is applied to each folded spectrum. Each of the two lowpass filters has a flat response to approximately 2.38 MHz, and a root raised cosine response rolloff between 2.38 and 3 MHz.

In a Weaver implementation, the root raised cosine bandpass filter is actually a pair of lowpass filters. Two 256 tap filters, operating at the 10.76 MHz sampling rate, are approximately equivalent to a brute force bandpass filter of 2048 taps, operating on a DSB signal at 4 times the symbol rate. Brute force VSB generation requires approximately 88.2 gigataps per second, while using the Weaver method only requires 11 gigataps per second - just one eighth of the computational "horsepower."

Use of Weaver modulation in the generation of ATSC signals has the following advantages:

1. Complex root-raised cosine filtering may be done at the lowest sampling rate of the system.
2. Since the sampling rate where the bulk of the filtering is done is low, digital filters may be multiplexed to conserve hardware.
3. Operation of finite impulse response (FIR) filters at the lowest possible sampling rate generally means that the order of the filter may be lower for a given

performance level. So, the filter can be shorter, simpler, slower, yet at the same time better than other implementations.

4. Because the bandwidth of the baseband signals is only 3 MHz instead of 6 MHz, subsequent interpolation filters will be considerably simplified over other methods. (The bandwidth of the interpolation filters is less.)

## V. Implementation

A digital television exciter is a multirate sampling system. This means that some functions are performed at low sampling rates while others are done at high sampling rates. Generally, basic filtering operations including adaptive linear equalization and vestigial sideband filtering are done at the lowest sampling rates. Nonlinear predistortion, where new frequencies are produced and the bandwidth is increased, is performed at higher sampling rates to avoid aliasing. Finally, digital intermediate frequency (IF) modulation is done at the final highest sampling rate.

For dual-mode operation, it is advantageous to use approximately the same highest sampling rate, in order to use the same analog reconstruction filter and analog up converter for both NTSC and ATSC. Fortunately, there is a convenient close convergence of NTSC and ATSC related clock frequencies at 86 MHz.

SMPTE 310 input data is transmitted at a symbol rate of approximately 10.76 MHz. SMPTE 244M or SMPTE 259M digital NTSC data is transmitted at a sampling rate of four times subcarrier which is approximately 14.318 MHz.

Eight times the ATSC symbol rate is approximately 86.098 MHz. This is close to 85.909 MHz, which is approximately 24 times subcarrier.

Use of a 86 MHz output sampling rate for both NTSC and ATSC allows use of a relatively high digital IF frequency centered at 21.5 MHz, approximately one quarter of the sampling rate, or one half of the Nyquist rate. Using a 21.5 MHz IF comfortably allows nonlinear predistortion sidebands to be generated which are at least three channels wide, or 18 MHz of bandwidth.

In the ATSC mode, baseband linear equalization and Weaver modulation are performed at the symbol rate. From there the signal is interpolated to four times the symbol rate. At this higher sampling rate, nonlinear predistortion is applied to correct for power amplifier nonlinearity. At this point, the 3 MHz wide signal may

increase to 9 MHz of bandwidth or more (corresponding to an IF bandwidth of 18 MHz or more).

Finally, the sampling rate of the orthogonal signals is increased to 86 MHz where they modulate orthogonal IF carriers, to produce the IF signal centered at 21.5 MHz. Figure 7 shows the various sampling rates and the nonlinear equalization applied at four times the symbol rate.

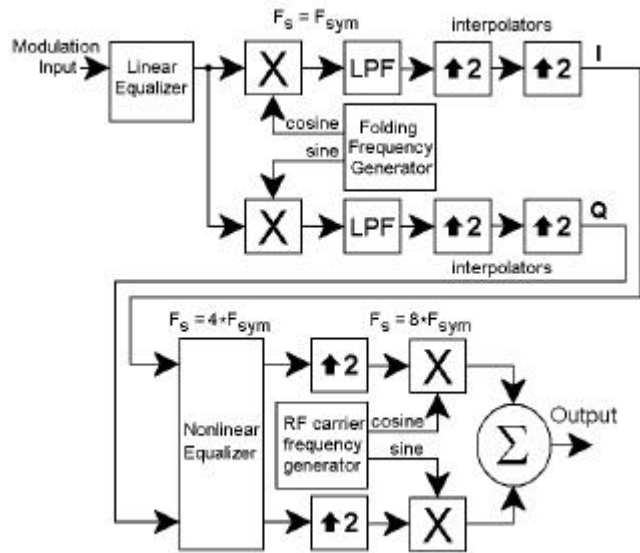

Figure 7 - Nonlinear Equalization at  $4 \cdot F_{sym}$

One quarter of the output clock is 21.52447552... MHz, which is close to 21.5 MHz. But it is desirable to produce an IF signal centered on exactly 21.5 MHz, because this makes the analog up converter easier to design. Furthermore, it is desirable to make the IF frequency independent of the input clock frequency. Also, it is necessary for some stations to produce channel offset frequencies to minimize interference. To achieve these objectives, the Weaver VSB modulator includes a frequency shifter. The frequency shifter is used to (1) center the output frequency on exactly 21.5 MHz, (2) compensate for input clock frequency errors, and (3) produce channel offset frequencies where required.

The frequency offset generator, which operates on the Weaver baseband signals, is shown together with a Weaver modulator in Figure 8.

To determine the offset frequency, the frequency of the SMPTE 310 input clock is measured against an accurate internal 10 MHz reference. The 10 MHz reference may be locked to GPS or to a rubidium standard. (The SMPTE 310 input frequency may vary as much as +/-

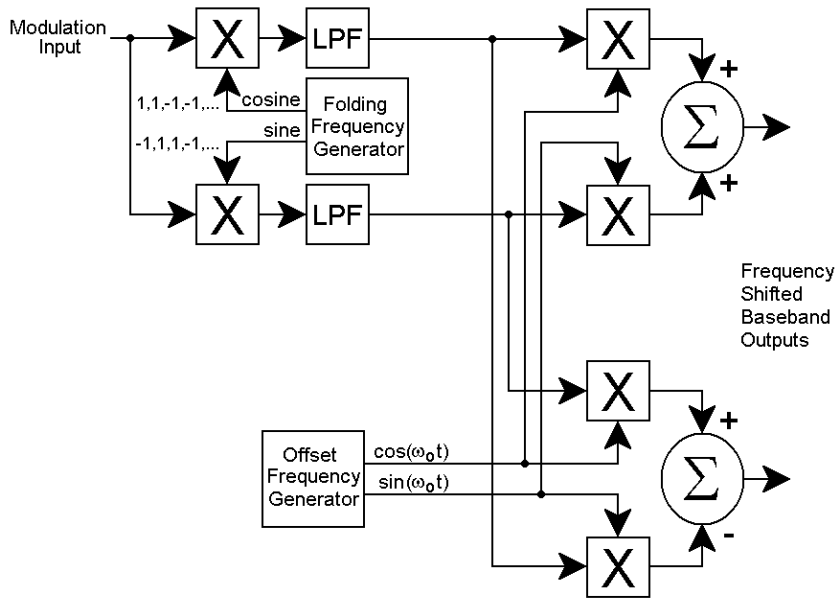

Figure 8 - Frequency Shifter

2.8 ppm, which would cause an IF frequency error of up to 60 Hz if uncorrected.) Using a 32 bit DDS, frequency precision is approximately 0.0025 Hz.

The basic Weaver VSB modulator (shown without linear and nonlinear equalizers) is shown in Figure 9.

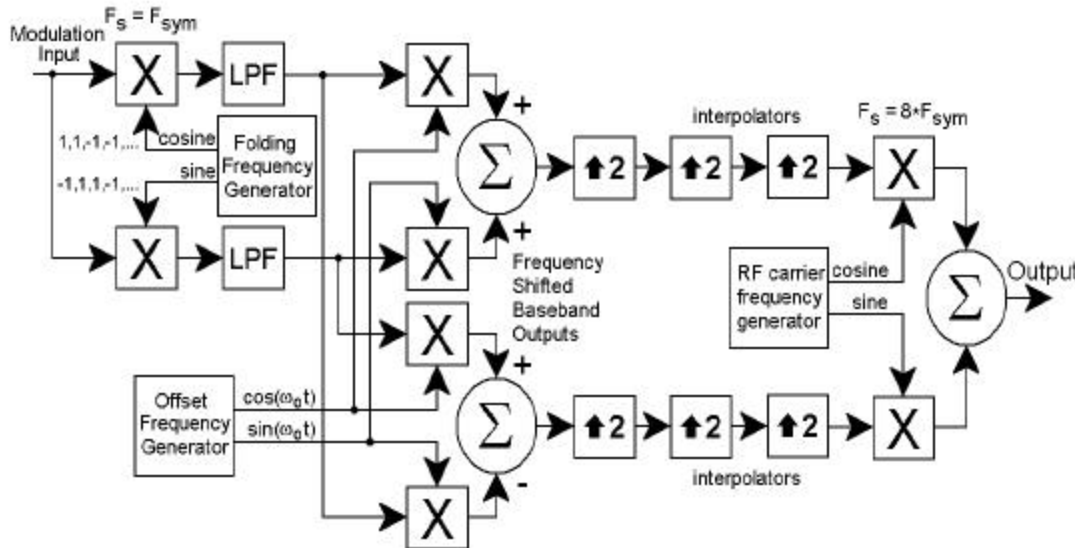

Figure 9 - Basic Weaver 8-VSB Modulator with Frequency Shifter

VI. NTSC Mode

Digital NTSC signals are described by SMPTE 244M (parallel) and SMPTE 259M (serial). A digital NTSC exciter should accept the SMPTE 259M signal as its input.

Although the generation of NTSC signals requires less severe filtering than the ATSC case, there are several considerations when using this same Weaver modulator architecture to produce NTSC signals. These issues are:

1. Unlike ATSC, the NTSC signal does not have symmetrical sideband shapes.
2. NTSC includes an aural carrier signal.
3. NTSC includes a receiver delay equalizer.

If we want to produce a frequency inverted (lower sideband) NTSC IF signal centered at 21.5 MHz, Figure 10 illustrates what the various frequencies will be.

If the transmitter uses common aural and visual amplification, the aural carrier will appear in the visual exciter's output. Transmitters with a separate aural

power amplifier will have a separate aural exciter.

Using the frequency scheme shown in Figure 10, the highest Weaver baseband signals will be produced by the upper IF sideband. Therefore, it will be the vestigial upper IF sideband that is shaped by the Weaver lowpass filters. The Weaver

lowpass filters will be flat to 2.5227... MHz and will cut

off by 3.0227... MHz. The sharp cutoff of the lower IF sideband is independently shaped at baseband by a simple video lowpass filter.

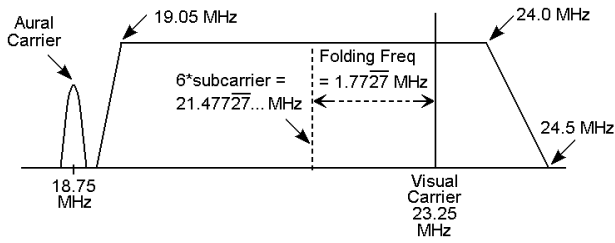

**Figure 10 - NTSC IF Spectrum Showing Weaver Folding Frequency**

The aural carrier, if introduced at baseband, would appear in the folded baseband signals at 2.727... MHz, which is within the transition band of the NTSC Weaver lowpass filter. The filter's slope would introduce undesirable incidental envelope modulation onto the aural carrier. Therefore, when this frequency scheme is used, the NTSC aural carrier, if amplified in common with the visual carrier, must be introduced subsequent to the Weaver modulation. Fortunately, this is easy to do because common direct digital synthesizer (DDS) chips generally produce quadrature sinusoidal (sine and cosine) outputs.

BTSC signals are still produced in the analog domain today. Therefore, the aural modulation input will accept a BTSC composite baseband signal. The BTSC signal, which has a bandwidth of some 120 kHz, is digitized at a submultiple of subcarrier. Then its sampling rate is increased to four times subcarrier or 14.318... MHz. At this point the BTSC signal frequency modulates a DDS.

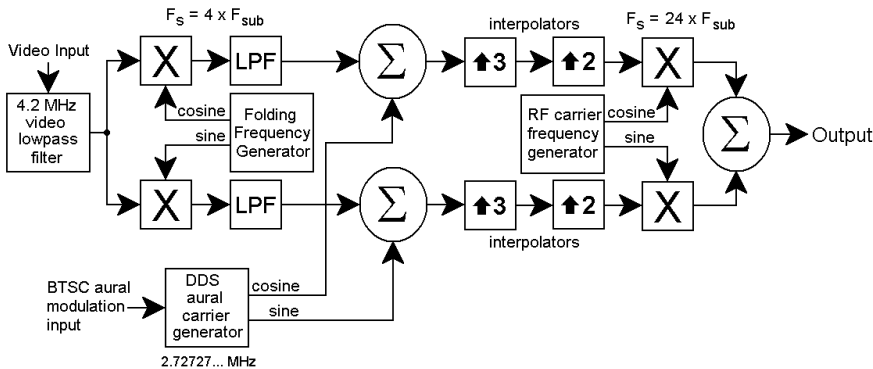

**Figure 11 - Weaver NTSC VSB Modulator**

The DDS produces frequency modulated quadrature sinewaves at 2.727... MHz, which are simply added to the Weaver baseband signals after lowpass filtering. This is shown in Figure 11.

Unlike the ATSC implementation, where the Weaver folding multipliers are trivial (multiplying only by +1 and -1), the NTSC folding frequency (1.7727... MHz) is not a round number. Therefore, that folding frequency is produced by another DDS and the multipliers that perform the modulation are of a nontrivial, general purpose type. However, they only need to operate at the four times subcarrier video sampling frequency (14.318... MHz). With a 32 bit DDS, frequency precision is approximately 0.003 Hz.

As is done in the ATSC case, channel offsets and compensation for frequency errors in the incoming SMPTE 259M serial bitstream are accomplished by adjusting the frequency of the folding frequency generator DDS.

**VII. The Transmitter System**

A complete transmitter system includes an exciter, a visual power amplifier system, and an adaptive linear and nonlinear equalization subsystem. Often in the case of NTSC, a separate aural power amplifier system and diplexer is included. ATSC transmitters will also include channel filters.

Power amplifier requirements differ between NTSC and ATSC service. In ATSC service, the signal is nearly stationary in the statistical sense. The transmitted signal resembles a band limited noise signal with a peak to average power ratio of approximately four to one. Average power remains nearly constant. Dissipation also remains nearly constant. The RF envelope, which determines the power supply currents that must be decoupled, is a wideband noise-like function.

For NTSC service, the average power varies, the peak power remains constant, and therefore the peak to average ratio varies. The power supply must be capable of delivering constant voltage in the presence of large low frequency video currents, related to vertical sync pulses and other components. Dissipation varies as a function of average picture level. So in some ways, NTSC service has more severe

requirements for an RF power amplifier. These include variable dissipation and power supply dynamic performance.

ATSC service has the more severe requirement when it comes to linearity. In-band nonlinearities affect EVM performance, while out of band nonlinearities affect the transmitter's spectral mask.

Adaptive equalization, both linear and nonlinear, can be performed using a non real time demodulation process to sample the transmitter's output. First, the transmitter's output is down-converted to the 21.5 MHz IF frequency. Next, a high speed A/D converter takes "snapshots" of the transmitter output. A floating point digital signal processor demodulates the snapshot in non real time. Finally, the results from the numerical demodulation are used to update linear and nonlinear equalizers, based on designs used in DAB transmitters.

For transmitters that use a separate aural power amplifier and notch diplexer in the NTSC mode, ATSC operation will require either bypassing of the diplexer or detuning of its notch resonators such that the diplexer bandwidth is extended to the entire 6 MHz channel width.

### **VIII. Conclusion**

Careful system architecture, use of reprogrammable logic devices, and the proper choice of system clock frequencies make it possible to produce a system that can transmit either NTSC or ATSC television signals. A reconfigurable transmission system offers more options and flexibility to broadcasters during the transition period to digital TV broadcasting.